

Build a Wall

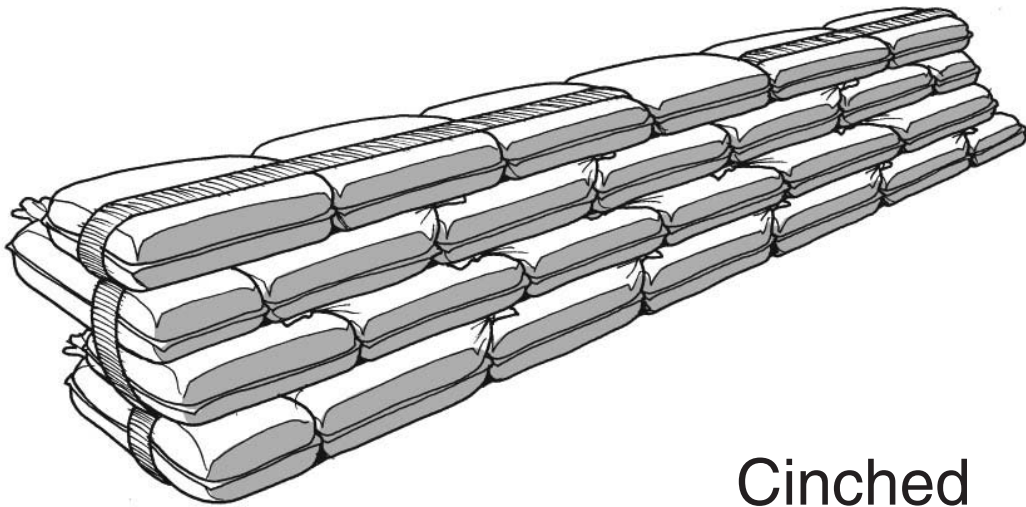

Cinched
Spiked

 **Envirolok**TM

(Patent Pending)

©2007 Agrecol Corporation

Build an Envirolok Wall

Spiked Cinched

Conditions

- Wall Height: 4' or less
- Soil Conditions: Compacted and stable
- Water: None present, dry and stable
- Erosion: Not a factor

Site Preparation

**Excavate a level foundation trough
16" wide and 3" deep.**

Excavated material (spoils) may be
used to backfill during construction.

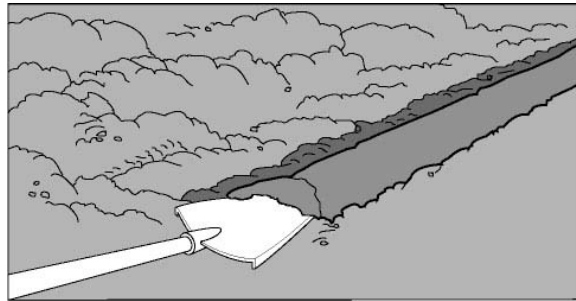

Site Preparation

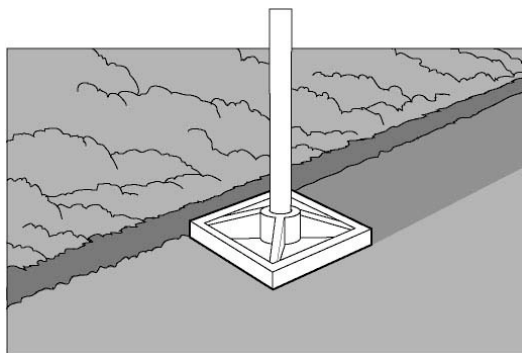

Tamp

Compact bottom of foundation trough
using hand tamper or equivalent.

Cinching

Cinching

Envirolok bag stabilizer is woven horizontally throughout the wall to prevent horizontal wall separation.

Cinching guards against bag displacement with ground-heave caused by freeze and thaw cycles

Cinching

- Loose stabilizer will not hold the wall in place.
- The stabilizer is secured with spikes and cinch bags.
- The stabilizer is anchored at both ends of the wall with a bag setup called an end-cap.
- In each course, cinch as many bags as necessary to make the stabilizer tight.
- Approximately every third or fourth bag can be cinched.

Cinch Bag

A cinch bag is a bag in the course which has been pulled out from under the bag stabilizer and placed on top of the bag stabilizer.

The weight of the bag pulls the stabilizer tight.

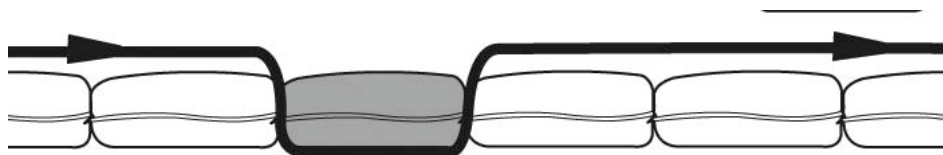

Cinching Diagram

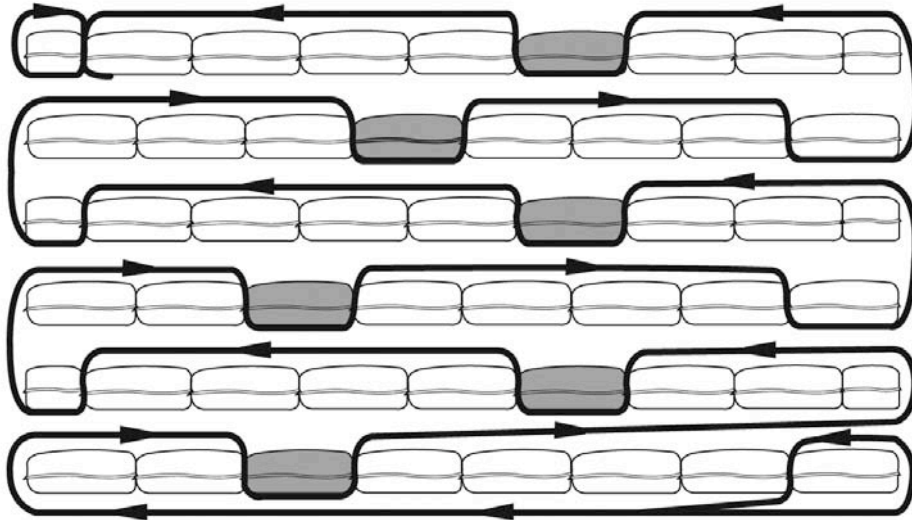

Cinching Curved Walls

Curved walls require more cinch bags than straight walls.

Use more cinch bags to make sure the bag stabilizer follows the curve of the wall.

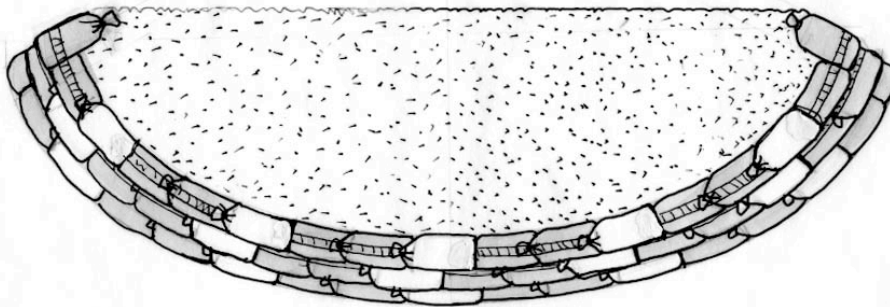

Bag Stabilizer

Can be tied in a knot to form one continuous strip.

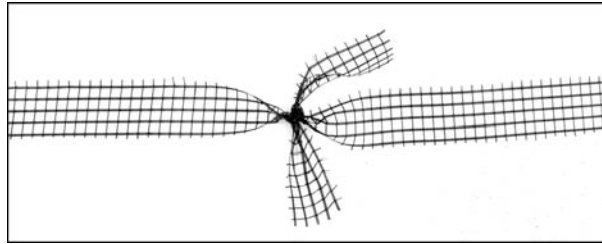

Or stabilizer can be overlapped.

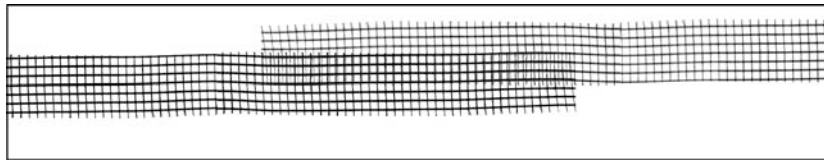

Foundation Course

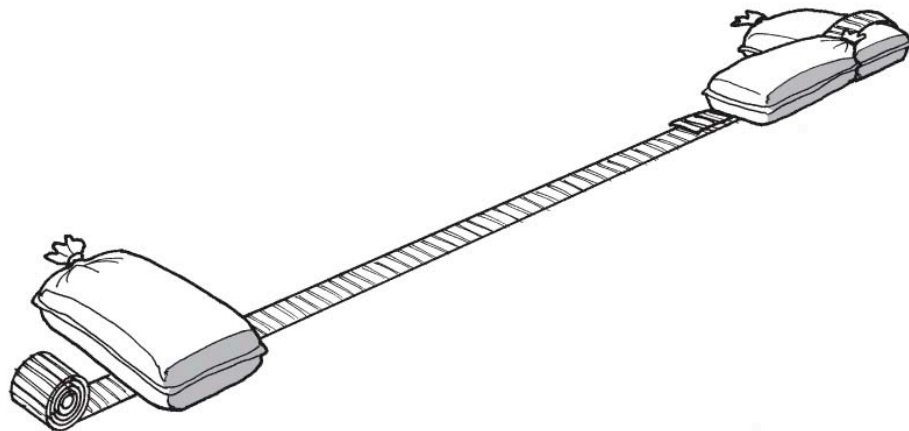

- A. Unroll the bag stabilizer on the ground the entire length of the wall. Anchor each end of the stabilizer with a bag.
 - The end of the roll of bag stabilizer should extend 5' beyond the right anchor bag. Pull a 5' tail of stabilizer around this right anchor bag.

Foundation Course

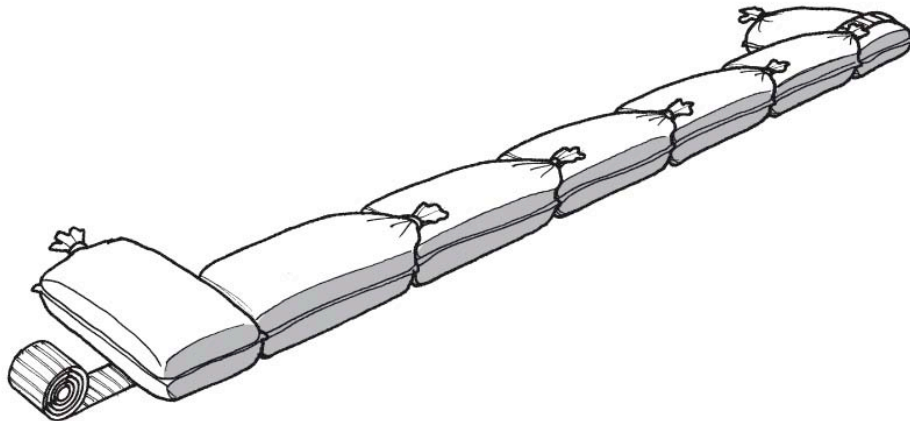

- b. Place filled bags next to each other, seam-side out, horizontally full length of the wall, on top of the cinching bag stabilizer.
- c. Tamp each bag to flatten it slightly to insure a solid and uniform structure.

Foundation Course

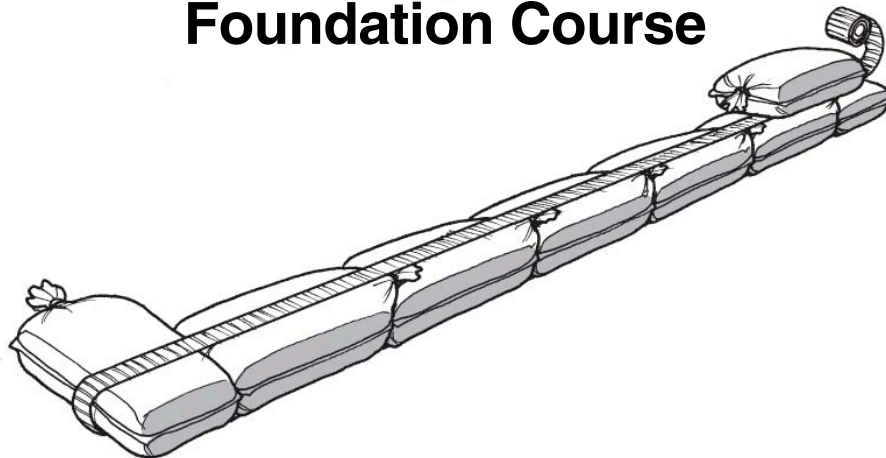

- d. Unroll the bag stabilizer across the top of the foundation course and pull it tight.
- e. Insert two spikes into the bag stabilizer lying on the right anchor bag.
- f. Place a bag on top of the right anchor bag. Make sure the snorkel faces inward. Tamp the bag. Wrap the cinching bag stabilizer up and around the anchor bag.

Foundation Course

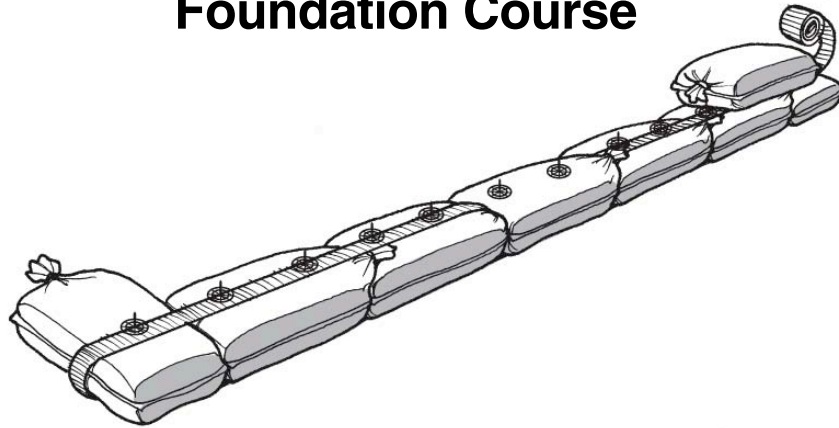

- g. Remove a bag from the course below the bag stabilizer, and place the bag on top of the bag stabilizer.
 - Cinch every three or four bags, or as many as necessary to pull the bag stabilizer tight.
- h. Tamp each cinched bag.
- i. Insert two spikes into the bag stabilizer on top of each bag on the course.
- j. Begin standard course.

Standard Course

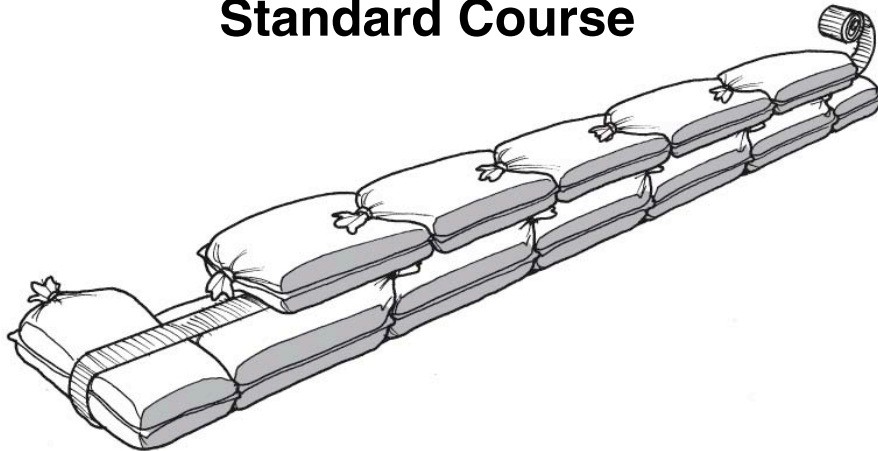

- a. Establish slope set-back. Place next course of filled bags next to each other, seam-side out, horizontally full length of the wall, with snorkel end of each bag lying on top of the previous bag.
 - Do not place the final bag at the left end of the course. This space will become the anchor bag for the left end cap.

Standard Course

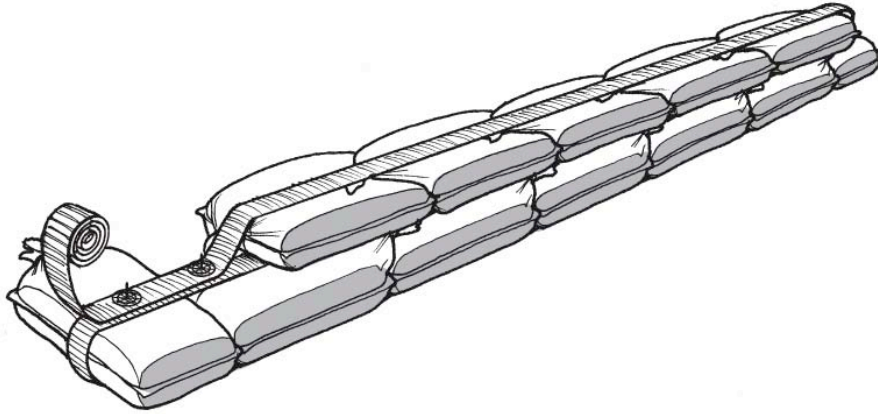

- b. After you have laid the entire course of bags, tamp each bag to flatten it slightly to insure a solid and uniform structure.
- c. Unroll the bag stabilizer over the course of bags and the empty spot.
- d. Insert two spikes into the foundation end bag in the empty spot. Be sure to check slope set-back before placing spikes.

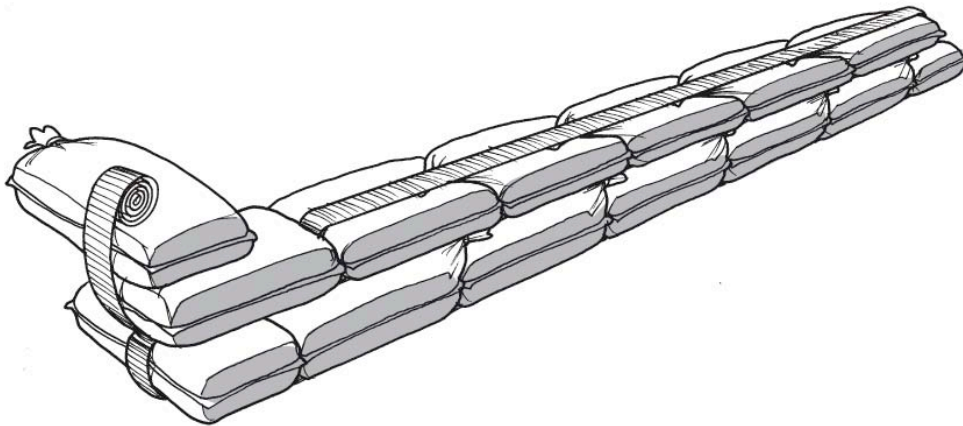

- e. Place the missing anchor bag into this spot on top of the stabilizer and spikes. Tamp it.
- f. Check slope set-back and insert spikes in the center of the contact area between courses.
- g. Place an additional anchor bag on top of this spiked anchor bag. This is the left end cap.
- h. Wrap the roll of bag stabilizer around the two stacked anchor bags in the left end-cap.

Standard Course

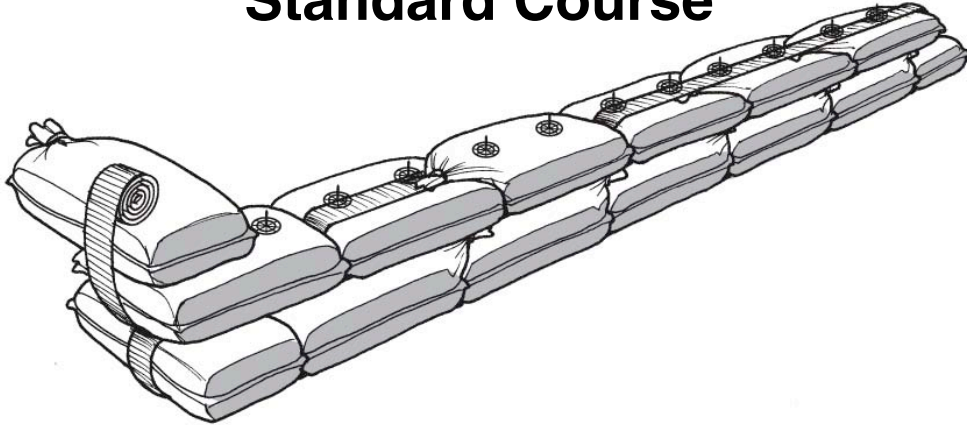

- i. Remove a bag from the course below the bag stabilizer, and place the bag on top of the bag stabilizer. Do this every three or four bags, or as necessary to pull the bag stabilizer taut.
- j. Tamp each cinch bag to flatten it slightly to insure a solid and uniform structure.
- k. Insert two spikes into the top of each bag in the course.
- l. Begin next course.

Standard Course

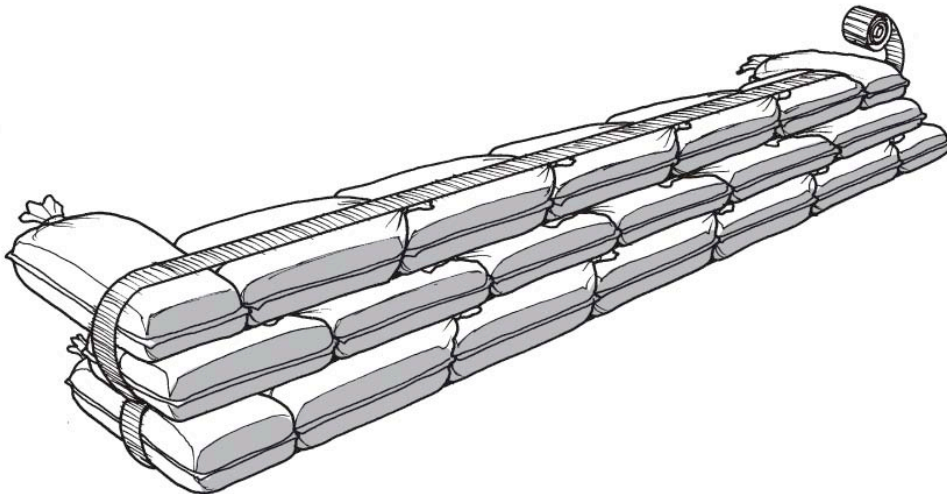

Continue laying courses.

Standard Course

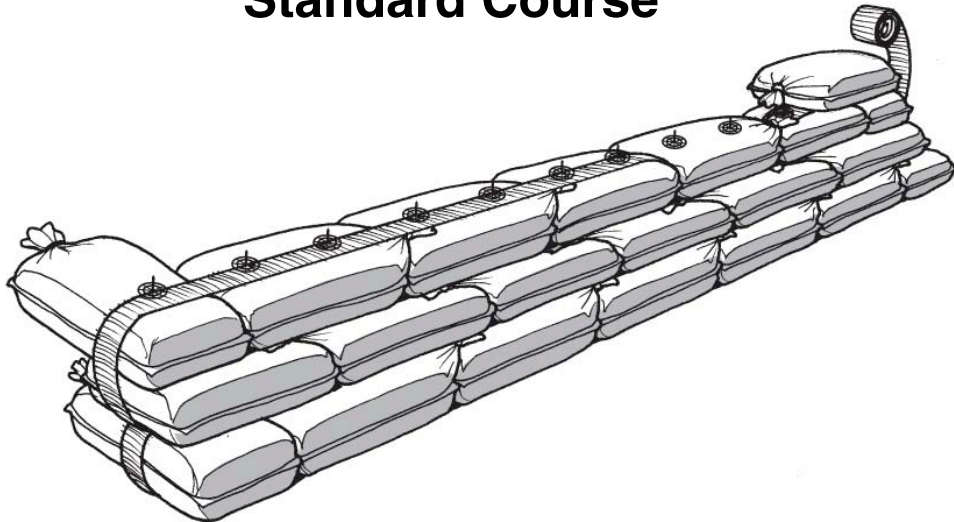

Additional standard courses are built the opposite as the previous course description.

The left end-cap becomes the right end-cap and vice-versa.

Final Course

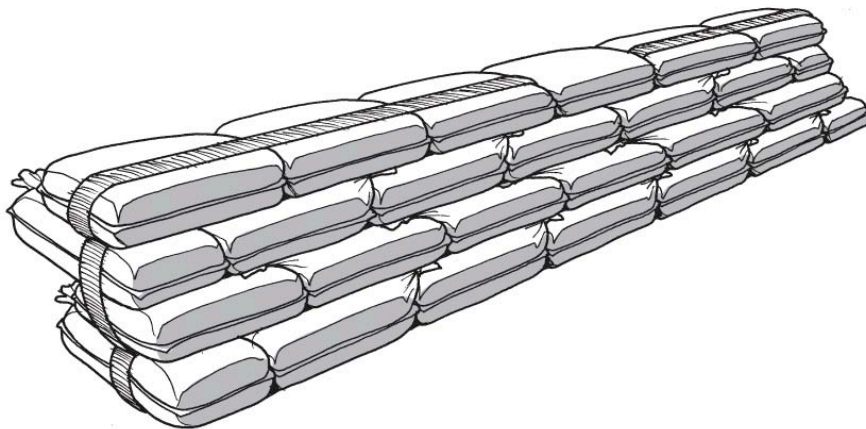

- a. Build until you reach the desired height of the structure.
- b. Place filled bags next to each other, seam-side out, horizontally full length of the wall, on top of the bag stabilizer and spikes.
 - Snorkels tucked. When you place bags for the final course (top of wall), fold the snorkel end of the bag and tuck it under the bag before laying the bags tightly together.

Final Course

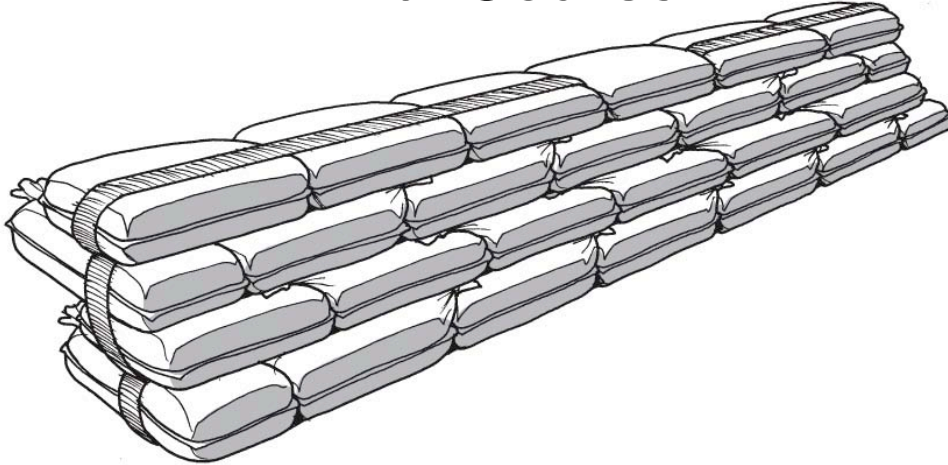

- c. Pull the bag stabilizer up and around the anchor bag on the top course. Unroll the bag stabilizer across the top course.
- d. Wrap the bag stabilizer around the end bag and tuck it below the adjoining bag. This “secures” the end of the stabilizer.

Final Course

- e. Cinch only enough bags to make the stabilizer tight. Do not over-cinch the top course.
- f. Do not put spikes into the top of the final course. This gives a finished look to the top course of the structure.
- g. Tamp the top of the wall to finish it.

Proceed to “Vegetating The Wall”